



emerald
freight express

GLOBAL • FREIGHT • MANAGEMENT

UNIT LOAD DEVICES

The term Unit Load Device (ULD) means any type of container with an integral pallet, or aircraft pallet whether or not owned by an IATA member, and whether or not considered to be aircraft equipped.

Aircraft ULDs

These are units that interface directly with an Aircraft loading and restraint system. They meet all normal restraint requirements without the use of supplementary equipment – providing they are loaded in accordance with the specific Aircraft Load and Balance Manual.

Such units become an integral part of the Aircraft structure, when loaded and are typically Certified Aircraft Containers or Pallet and Net assemblies.

Note: The Aircraft Load and Balance Manual includes controls for-

- The type, number and positions, that ULDs can be loaded.
- Their allowable Max Gross Weights
- Acceptable alternate ULD loading arrangements such as:-
 - Carriage of loads exceeding normal allowances.
 - Load limitations with broken/missing restraint components.

These controls may effect direct interlining of ULDs between Aircraft Types.

Aircraft ULDs may be loaned to shippers and agents for loading purposes provided they can prove that they are equipped and capable to handle them in accordance with the Aircraft Load and Balance Manual(s).

Non-Aircraft ULDs

These units do not interface with the aircraft restraint system. They must be registered with IATA and conform to IATA standard specifications. Non-aircraft ULDs, in order to be eligible for rating incentives, must be owned by a shipper or agent.

RATING OF ULDs

Method A

On certain routes, rating Method 'A' charges shall apply at the request of the

shipper for consignments carried from airport of departure to airport of destination entirely in ULDs. In order to qualify for Bulk Unitisation Rates, the cargo must be carried from origin to destination in the same ULD.

The charge for the consignment shall consist of a flat minimum (pivot) charge for a specified pivot weight above which an additional charge (over-pivot rate) per kilo or pound will apply. Charges for airline owned Aircraft ULDs shall be based on the actual gross weight less the actual tare weight of the ULD.

Charges for shipper or agent owned Aircraft ULDs or Non-Aircraft ULDs shall be based on the actual gross weight less the actual tare weight, but not more than the IATA tare weight allowance for the particular ULD.

Method B

Discounts and tare weight allowances only apply when shipments are delivered to the airline packaged in registered shipper-owned, standard size non-aircraft units. Charges are based on the actual weight of the shipment, less the tare weight allowance, but not less than the minimum chargeable weight for the particular container used. The tare weight allowance is always that which is printed on the actual container. A discount is also granted under this programme, which refers to each type of non-aircraft ULD. The amount of discount can be deducted from the weight charge, but shall not exceed 10% of the charges applicable to the consignment carried in the ULD. In no case shall the charges established under method A be applied cumulatively with the discount authorised under rating method B.

Dangerous Goods, Live Animals and Human Remains will not be accepted in a ULD, either rated under methods A or B.

Further information on the rules applicable to ULDs and full rating tables can be obtained from: The Air Cargo Tariff (TACT). ABC Air Cargo Guide, British Airways Worldwide Cargo Tariff (Mini Tariff) or from British Airways World Cargo offices.

UNIT LOAD DEVICES

LD9
AAP

RATE CLASS 5

Wide body aircraft. Full width lower deck container. Suitable for the following aircraft: ■ Boeing 747, 767 & 777

Volume	350 cu. ft. (10.0 cu. m.)		
Tare weight	200 kgs/440 lbs		
Max Gross Weight	747	767	777
	6033kgs/13273 lbs	4626kg/10501 lbs	4626kg/10501 lbs

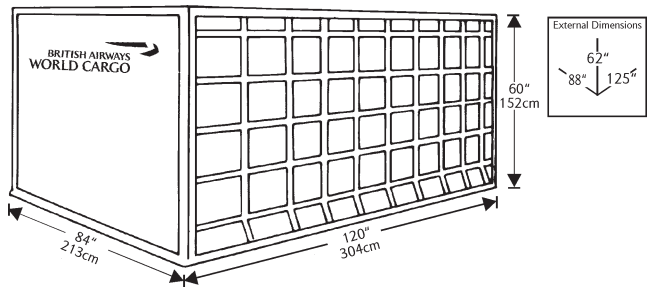

UNIT LOAD DEVICES

LD3 AKE

RATE CLASS 8

Wide body aircraft. Half width lower deck container. Suitable for the following aircraft: ■ Boeing 747, 767, 777, 757-200F

Volume 150 cu. ft. (4.2 cu. m.)

Tare weight 72 kgs/158 lbs

Max Gross Weight 1588 kgs/3493 lbs

Weight

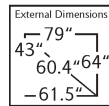
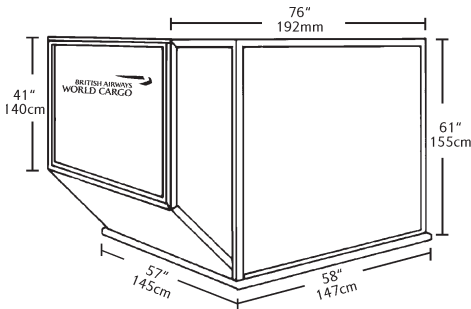

LD11 ALP/PLA

RATE CLASS 6

Wide body aircraft. ALP: Full width lower deck container.
PLA: Full width lower deck pallet

Suitable for the following aircraft: ■ Boeing 747 & 777

	ALP	PLA
Volume	240 cu. ft. (6.8 cu. m.)	245 cu. ft (7.0 cu. m.)
Tare weight	185 kgs/407 lbs	73 kgs/161 lbs
Max Gross Weight	747 & 777	747 & 777
Weight	3175 kgs/6985 lbs	3175 kgs/6985 lbs

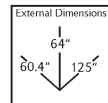
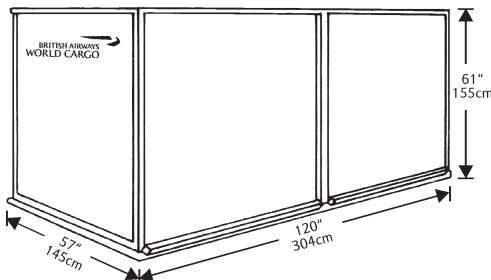

Centre post swings clear for loading

UNIT LOAD DEVICES

PAP/P1P/PAG for 757-200 Freighter

RATE CLASS 5

Wide body aircraft. Full width lower deck container. Suitable for the following aircraft: ■ Boeing 747, 767, 777, 757-200F

Volume 349 cu. ft. (9.83 cu. m.)

Tare weight 120 kgs/264 lbs

Max Gross Weight 4264 kgs/9402 lbs

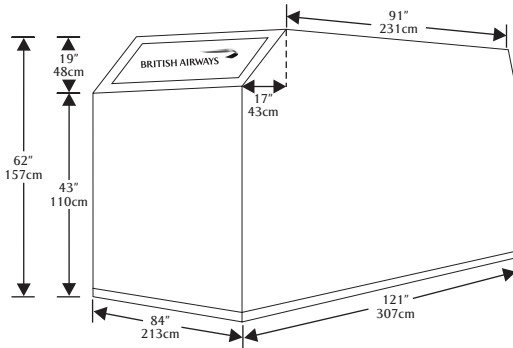

PAP/P1P/PAG

RATE CLASS 5

Wide body aircraft. Full width pallet with net.

Suitable for the following aircraft: ■ Boeing 747, 767, 777

Volume 240 cu. ft. (11.9 cu. m.) (with allowable overhang)

Tare weight 120 kgs/264 lbs

Max Gross Weight 747 767 777

6033 kgs/13273 lbs 4626kgs/10501 lbs 4626kgs/10501 lbs

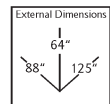
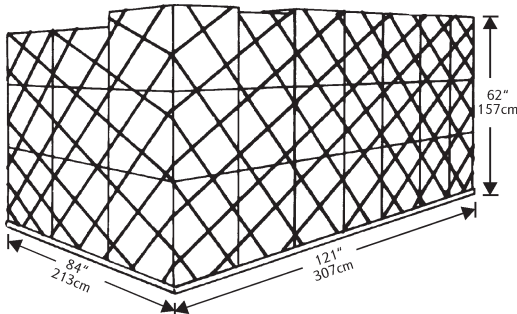

AKH

Lower deck container suitable for the following aircraft: ■ A320

Volume 120 cu. ft. (3.4 cu. m.)

Tare weight 76 kgs/167 lbs

Max Gross Weight 1134 kgs/2499 lbs

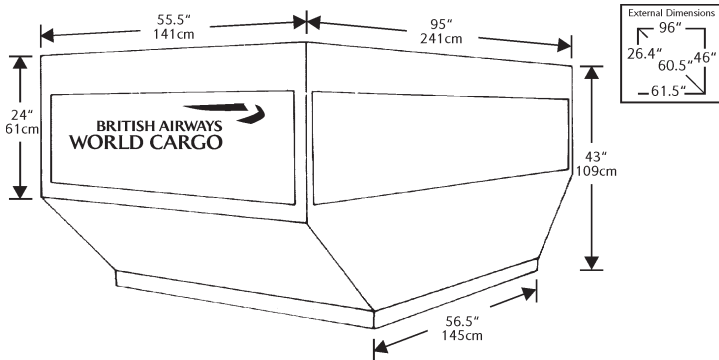

UNIT LOAD DEVICES

PMC

RATE CLASS 5

Wide body aircraft. Full width pallet with net. Suitable for the following aircraft: ■ Boeing 747, 767, 777

Lower deck pallet suitable for the following aircraft: ■ Boeing 747 & 767

Volume	450 cu. ft. (12.7 cu. m.)	
Tare weight	130 kgs/286 lbs	
Max Gross Weight	747	767
	5034 kgs/11075 lbs	5103 kgs/11227 lbs

Please note that the maximum gross weight is variable for the different aircraft types, in case of transfer.

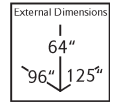
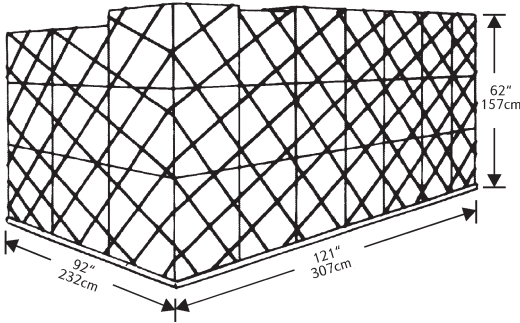

LD2
APE

Wide body aircraft. Half width lower deck container. Suitable for the following aircraft: ■ Boeing 767

Volume	120 cu. ft. (3.5 cu. m.)
Tare weight	70 kgs/154 lbs
Max Gross Weight	1225 kgs/2700 lbs

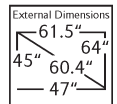
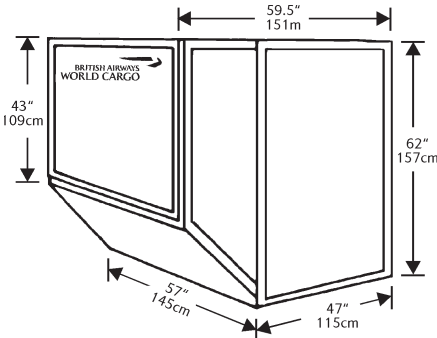

AQF

Lower deck container. Suitable for Boeing 767 only.

Volume 253 cu. ft. (7.9 cu. m.)

Tare weight 118 kgs/260 lbs

Max Gross Weight 2449 kg/5400 lbs

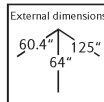
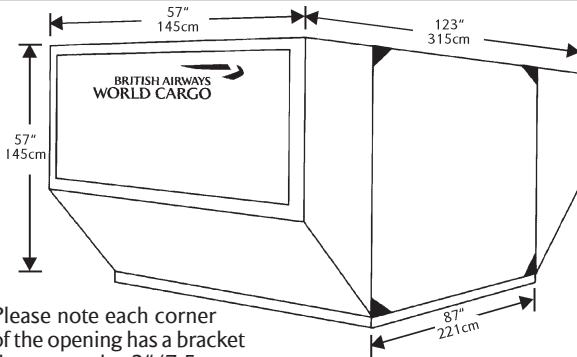

Please note each corner of the opening has a bracket that protrudes 3"/7.5cm

AIRCRAFT DIMENSIONS

BOEING 747-400

The Boeing 747-400 is a wide bodied long range passenger aircraft capable of carrying approximately 20 tonnes of cargo in addition to a full passenger load, although this figure varies dependent upon the route. The forward hold (compartments 1 & 2) and the centre hold (compartments 3 & 4) are designed for the carriage of ULD's only. Compartment 5 is for the carriage of loose cargo.

Door sizes

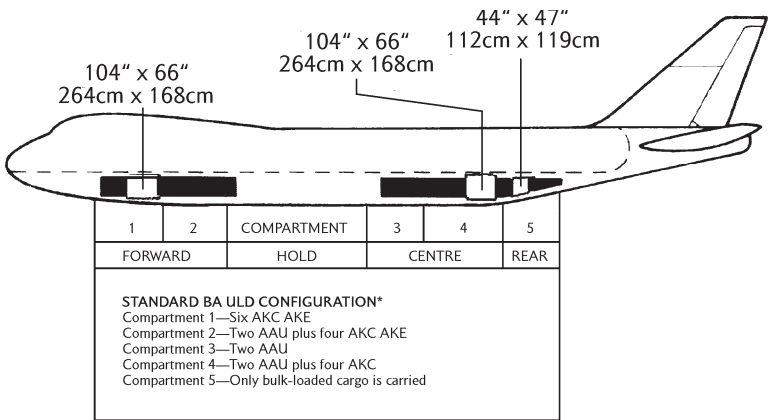

*The following equipment can be used in place of the 'Standard Configuration' to suit load requirements and to allow interchangeability with other carriers or aircraft.

Compartments 1 & 2 – AAU/ALP lower deck.

PAP/PLA pallets and nets.

Compartments 3 & 4 – PAP/PAG pallets with nets or ALP.

AIRCRAFT DIMENSIONS

BOEING 777

The 777 is a wide body, medium to long range aircraft which can carry up to 14 tonnes (99.8 cu. metres) of cargo and mail. The aircraft has 5 holds (3 compartments), 4 (2 compartments) of which are designed to carry unit load devices with the compartment five (rear hold) available for bulk loaded cargo and mail.

Door sizes

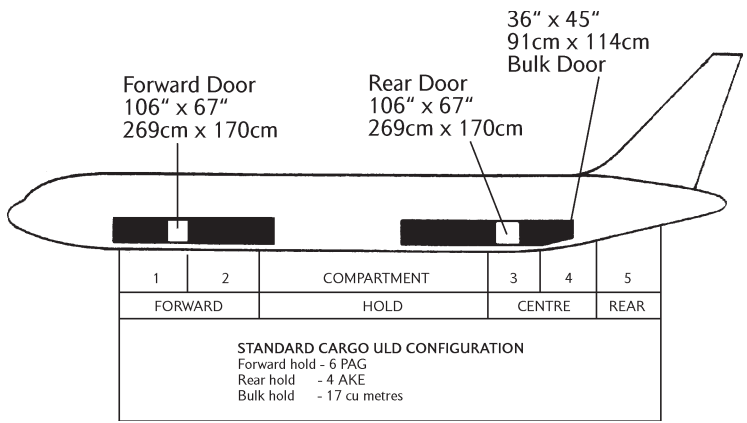

AIRCRAFT DIMENSIONS

BOEING 767

The Boeing 767 is a medium range aircraft which can carry approximately 9 tonnes of cargo in addition to a full passenger load. The aircraft has two lower deck holds comprising five compartments. The forward hold, comprising compartments 1 & 2, together with compartments 3 & 4 in the rear hold, are designed for the carriage of ULD's, whilst compartment 5 in the rear hold is for bulk-loading only.

Door sizes

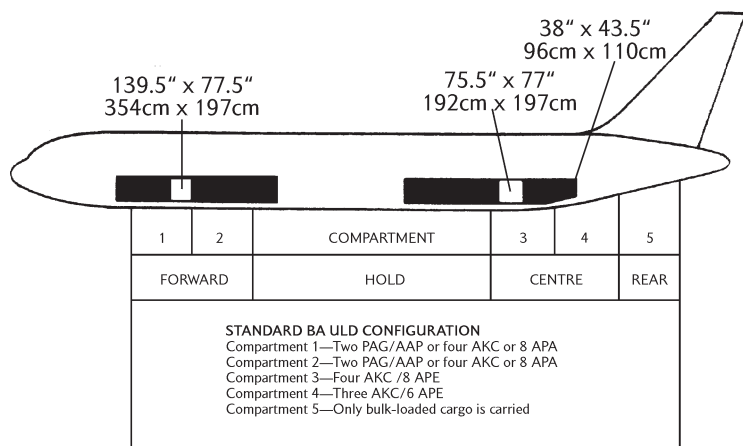

AIRCRAFT DIMENSIONS

BOEING 757

The 757 is narrow-bodied, short to medium range aircraft which can carry approximately 5 tonnes of cargo together with a full passenger load. The aircraft has two underfloor holds consisting of five compartments. The forward hold (compartments 1 & 2) is fitted with a three-bin sled installation which is extendable from about 20" behind the forward hold door to the rear of the hold. The rear hold is divided into two sections. The forward section (compartments 3 & 4) is fitted with a two-bin sled installation and the rear section (compartment 5) is a bulk compartment. Cargo and mail are loose loaded on this aircraft, which does not carry Unit Load Devices.

Door sizes

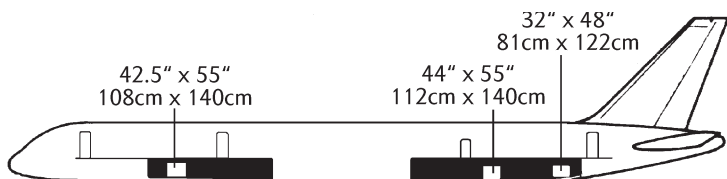

Compartment	1	2		3	4	5
HOLD	FORWARD			CENTRE		REAR
Max. Comp. load	800	3464	(Kg)	2810	1699	2476
Max. Floor loading	732	732	(Kg/Sq.m.)	732	732	732
Max. Floor loading	68	68	(Kg/Sq.ft.)	68	68	68
Usable Volume	4.64	13.05	(Cu.m.)	13.56	6.85	6.62
Usable Volume	164	461	(Cu.ft.)	479	242	234

Hold Dimensions

COMPARTMENT 1 & 2

	Width											
Height		5	10	15	20	25	30	35	40	45	50	inches cm
		12	25	38	50	63	76	89	101	114	127	
	40	95	95	95	95	85	75	70	65	55	45	
	101	241	241	241	241	216	190	178	165	140	114	

COMPARTMENT 3/4/5

	Width											
Height		5	10	15	20	25	30	35	40			inches cm
		12	25	38	50	63	76	89	101			
	40	110	110	110	95	85	75	68	60			
	101	279	279	279	241	216	190	172	152			

AIRCRAFT DIMENSIONS

BOEING 757-200 Freighter

The 757-200F is narrow-bodied, short to medium range aircraft which can carry 25.8 tonnes of cargo.

Normal Palletisation Arrangement

14 ULD 125" x 88"/317cm x 223cm
 +1 ULD 108" x 60.4"/273cm x 153cm



Door sizes

Main cargo door	134" x 86"/3.40m x 2.18m
Fwd belly door	55" x 42.5"/1.40m x 1.08m
Rear belly door	54" x 44"/1.40m x 1.12m
Cargo door sill	149"/3.79m
Belly door sill fwd	97"/2.46m
Belly door sill rear	93"/2.36m

Max Gross Weight: 757-200 Freighter

2 Positions	4264kg/9402lbs
2 Positions	2222kg/4899lbs
8 Positions	2268kg/5000lbs
1 Position	2132kg/4701lbs
1 Position	2040kg/4498lbs

AIRCRAFT DIMENSIONS

AIRBUS

A319

The A319 is a narrow-bodied, short-haul passenger aircraft which can carry up to 1 tonne of cargo and a full passenger load. The aircraft has two holds, consisting of three compartments, which are designed to carry Unit Load Devices or loose loaded cargo. British Airways will operate these aircraft loose loaded.

Door sizes

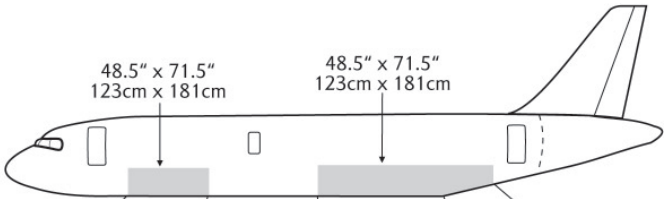

	1	COMPT NUMBER	4	5
	FORWARD	HOLD	REAR	
Max. Comp Load	2268	(kg)	3021	1497
Max. Floor Loading	488	(kg/sq. m.)	488	732
Max. Floor Loading	45.4	(kg/sq. ft.)	45.4	68
Usable Volume	8.16	(Cu. m.)	11.38	7.22
Usable Volume	288	(Cu. ft.)	402	255

AIRCRAFT DIMENSIONS

AIRBUS

A320

The A320 is a wide-bodied short-haul passenger aircraft which can carry 2 tonnes of cargo and a full passenger load. This aircraft has three holds, two of which are designed to carry Unit Load Devices and the other hold for bulk-loaded cargo.

Door sizes

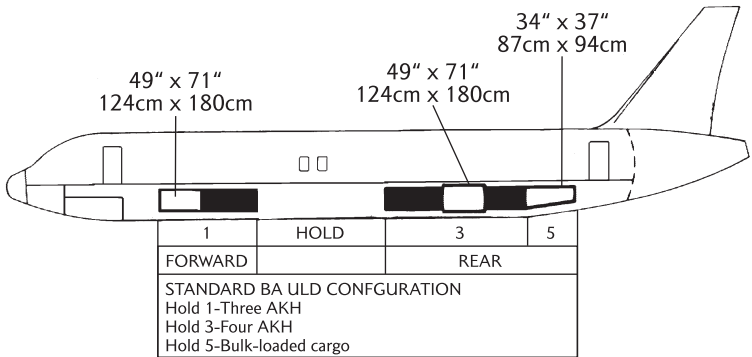

AIRCRAFT DIMENSIONS

BOEING 737

The 737 is a narrow-bodied, short-haul aircraft which is capable of carrying between 2–6 tonnes of cargo in addition to a full passenger load dependent on each route. This aircraft has two holds consisting of four compartments, all of which are designed for the carriage of loose-loaded bulk cargo and mail. The 737 does not carry Unit Load Devices.

Door sizes

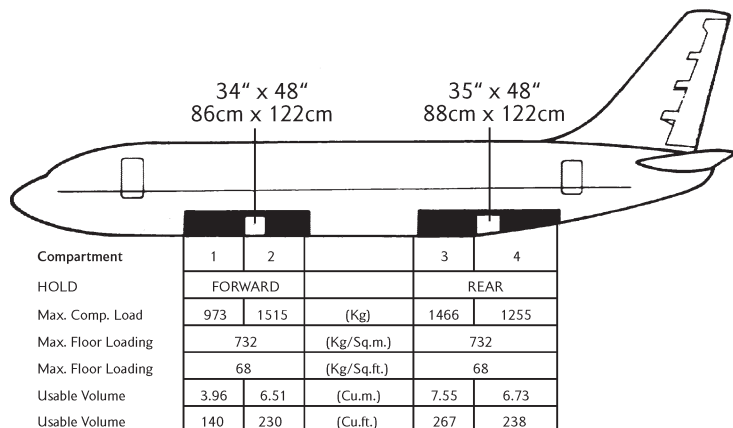

Hold Dimensions

		Width				
		Up to				inches
		30	35	40	42	
		76	88	101	106	cms
Height	10	100	100	100	100	
	25	254	254	254	254	
	14	100	100	100	96	
	35	254	254	254	243	
	18	100	100	100	96	
	45	254	254	254	243	
	22	100	100	100	96	
	55	254	254	254	243	
	26	100	96	96	96	
	66	254	243	243	243	
	30	100	96	95	86	
	76	254	243	241	218	
34	100	20	20	20		
86	254	50	50	50		